



NodeMCU-32 Specification

Version V1.3
Copyright ©2020

Disclaimer and copyright notice

The information in this article, including the URL address for reference, is subject to change without prior notice. The Documentation is provided "as is" without any warranty, including any warranties of merchantability, fitness for a particular purpose, or non-infringement, and any warranties mentioned in the proposal, specification or sample. This document is not responsible for any infringement of any patent rights arising out of the use of the information in this document. No license, express or implied, by estoppel or otherwise, is hereby granted.

The test data obtained in this paper are all obtained by Ai-Thinker laboratory, and the actual results may be slightly different. The Wi-Fi alliance membership mark is owned by the WiFi alliance.

All trade mark names, trademarks and registered trademarks mentioned herein are the property of their respective owners and are hereby declared.

The final interpretation right is owned by Shenzhen Ai-Thinker Technology Co., Ltd.

Note

The contents of this manual may be changed due to the version upgrade of the product or other reasons. Shenzhen Ai-Thinker Technology Co., Ltd. reserves the right to modify the contents of this manual without any notice. This manual is only used as a guide, and Shenzhen Ai-Thinker Technology Co., Ltd. makes every effort to provide accurate information in this manual, but Shenzhen Ai-Thinker Technology Co., Ltd. does not ensure that the contents of the manual are completely true. All statements and information in this manual, and the recommendations do not constitute for any warranty, express or implied.

Change History of Revision

Version	Date	Contents of Revision Change	Compilation	Verify
V1.0	2016.10.06	Initial release	Xiaofei Yang	
V1.1	2018.04.04	Information changes	Xiaofei Yang	
V1.2	2019.10.24	Version update	Yiji Xie	
V1.3	2020.04.22	Information changes	Yiji Xie	

CONTENT

1. Product overview.....	5
2. Electrical parameter.....	7
3. Appearance size.....	9
4. Pin definition.....	10
5. Schematics.....	13
6. Design Guidance.....	13
7. Reflow Welding Curve.....	14
8. Package Information.....	15
9. Contacts.....	15

1. Product overview

Nodemcu-32s module is developed by Anxinke Technology. At the heart of this module is the ESP32 chip, which is available extended, adaptive features. two CPU cores can be controlled separately. A clock frequency adjustment range of 80 MHz to 240MHz, support RTOS, is a universal Wi-Fi +BT +BLE MCU module.

Nodemcu-32s module integrates traditional Bluetooth, low power Bluetooth and Wi-Fi. Has a wide range of applications: Wi-Fi support for a wide range of communication connections and direct connection to the Internet through routers; Bluetooth allows users to connect Cell phone or broadcast BLE Beacon to facilitate signal detection. Data transfer rates up to 150 Mbps, supported by the module. Antenna output power up to 20 dBm, can achieve maximum range of wireless communication. So this module has a leading industry in high integration, wireless transmission distance, power consumption and network connectivity performance is excellent.

ESP32 operating system is LwIP freeRTOS, with hardware acceleration 1.2. Chip also supports OTA encryption upgrade, easy for users to continue to upgrade after product release.

Features

- 802.11b/g/n (802.11n, Speed up to 150Mbps)
- WIFI frequency range 2400~2483.5MHz
- Adjusting range of clock frequency for 80 MHz to 240 MHz, support RTOS
- Built-in 2 channels 12 bit high precision ADC, up to 18 channels
- Support UART/GPIO/ADC/DAC/SDIO/PWM/I2C/I2S interface
- Support multiple sleep modes, ESP32 chip sleep current less than 5 μ A
- Embedded Lwip protocol stack
- Supporting STA/AP/STA AP operating mode
- Support for local serial port upgrades and remote firmware upgrades (FOTA)
- Generic AT instructions can be used quickly

Parameters

Figure 1 Main Parameter

Model	NodeMCU-32
Package	DIP38(2.54mm standard pin header)
Size	25.4mm(W)*48.3mm(H) ±0.2 mm
Antenna	PCB antenna/IPEX external antenna
Frequency Range	2400 ~ 2483.5MHz
Operating Temperature	-20 °C ~ 70 °C
Storage Environment	-40 °C ~ 125 °C , < 90%RH
Power supply range	Micro USB supply voltage 4.75 V~5.25 V, recommended 5.0 V , supply voltage 3.0 V ~3.6 V, supply current 500 mA, recommended 3.3 V
Support Interface	UART/SPI/SDIO/I2C/PWM/I2S/IR/ADC/DAC
IO	3 (reserved)
UART Baut	Support 110 ~ 4608000 bps , default 115200 bps
Security	WEP/WPA-PSK/WPA2-PSK
SPI Flash	Default 32Mbit, Max support 128Mbit
Certification	FCC/CE-RED/IC/TELEC/KCC/SRRC/NCC/BQB/RoHS/REACH

2. Electrical parameter

Electrical Characteristics

Absolute maximum ratings

Any exceeding the following absolute maximum ratings may cause chip damage

Name	Min	Typ	Max	Unit
Micro USB voltage supply	4.75	5.0	5.25	V
Power supply voltage	2.6	3.3	3.6	V
Operating temperature	-20	-	+70	°C
Storage temperature	-40	-	+125	°C

WiFi Radio Performance

Description	Typ	Unit
Operating frequency	2400 - 2483.5	MHz
Output Power		
11n mode, PA output power	13±2	dBm
11g mode, PA output power	14±2	dBm
11b mode, PA output power	17±2	dBm
Sensitivity		
CCK, 1 Mbps	<= -98	dBm
CCK, 11 Mbps	<= -90	dBm
6 Mbps (1/2 BPSK)	<= -93	dBm

54 Mbps (3/4 64-QAM)	≤ -75	dBm
HT20 (MCS7)	≤ -73	dBm

Bluetooth Radio Performance

Description	Min	Typ	Max	Unit
Output characteristics				
Transmit frequency	-	+7.5	+10	dBm
Receiving characteristics				
Receiving sensitivity	-	-98	-	dBm

3. Appearance size

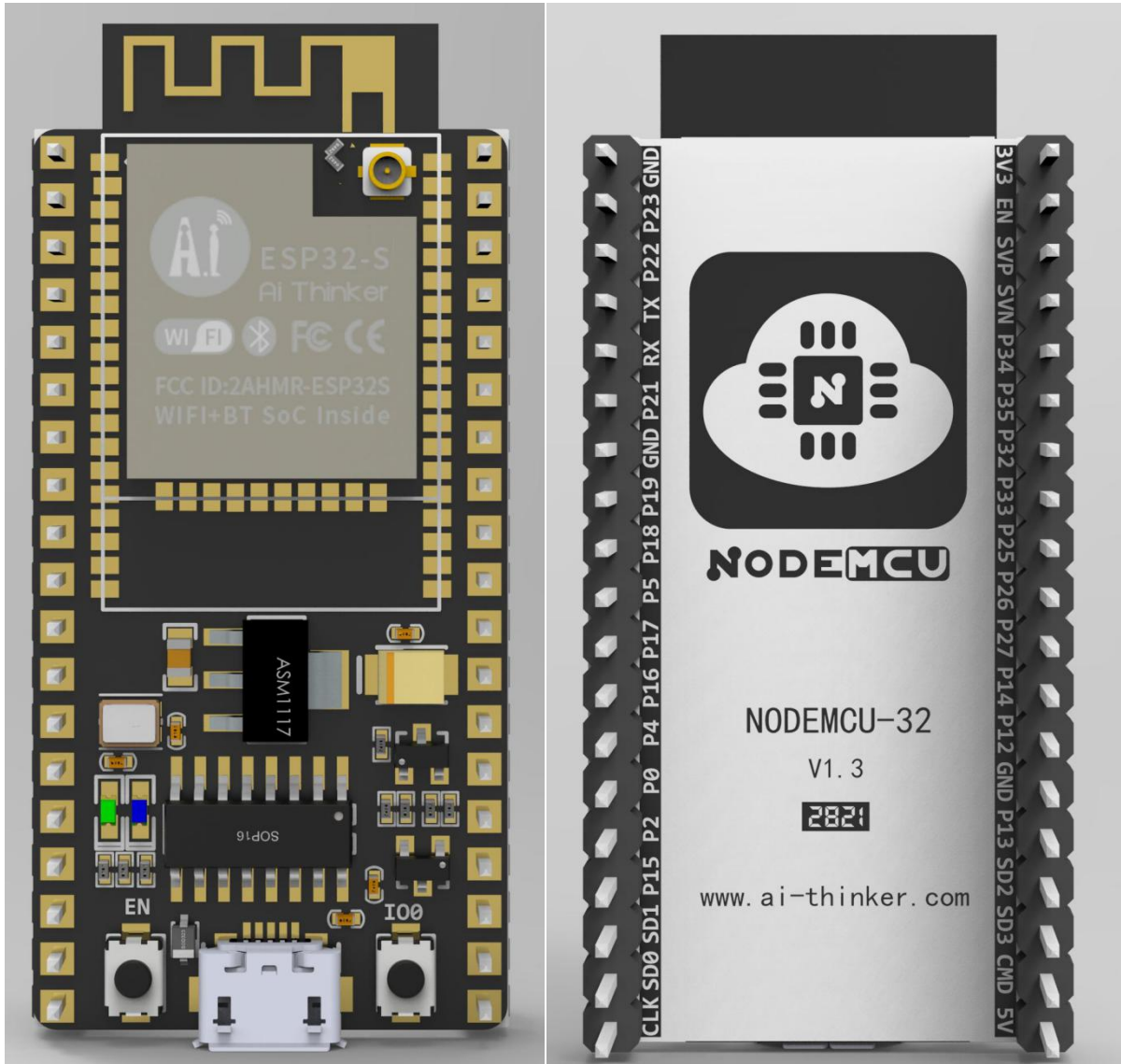

4. Pin definition

A total of 38 interfaces are connected NodeMCU-32_V1.3 the development board module, refer to below pin diagram, pin function definition table is interface definition.

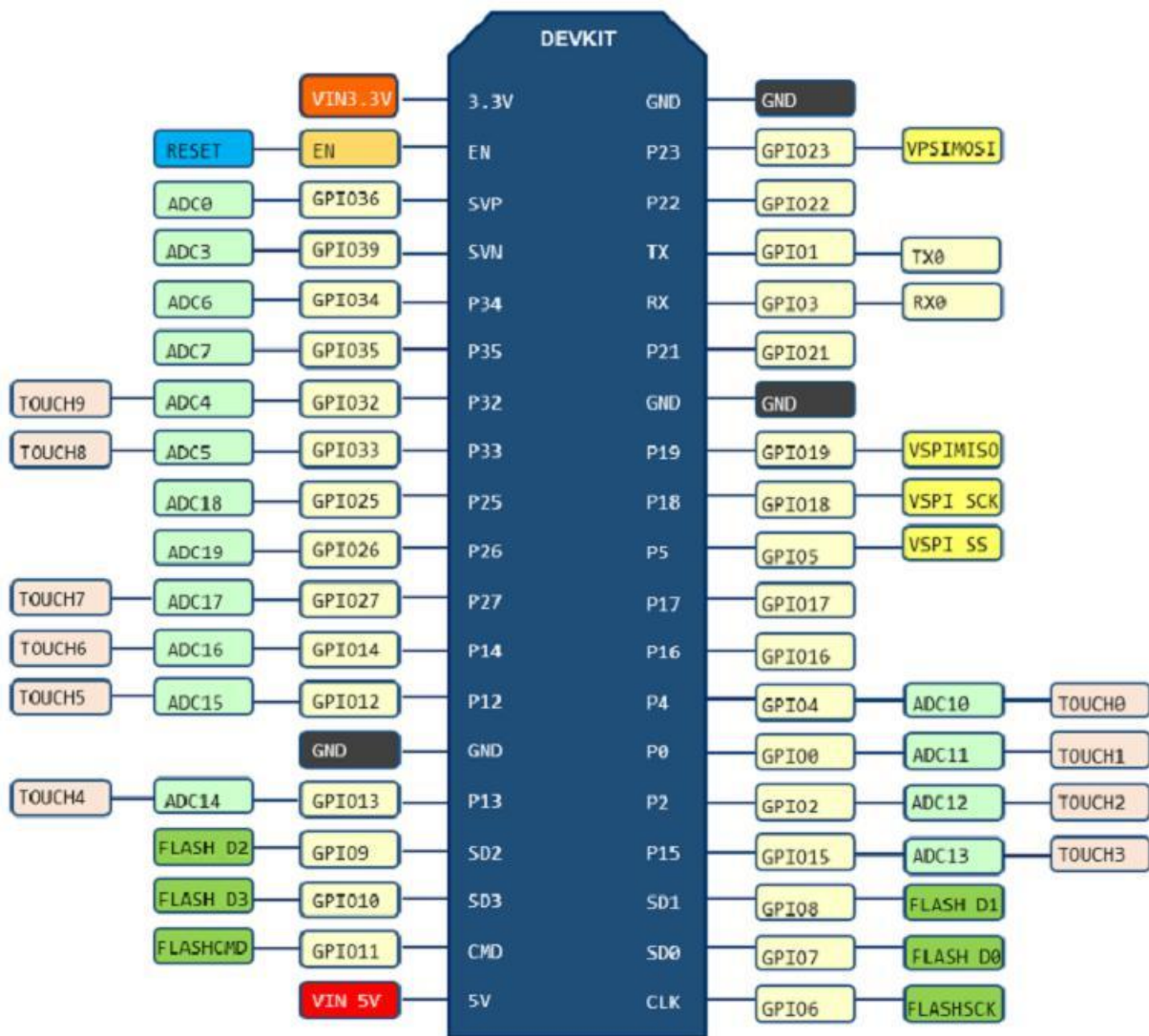

NodeMCU-32 Pin diagram

Table 2.2 Pin function definition

No.	Name	Function
1	3.3V	Power supply
2	EN	Enable module, high level efficient
3	SVP	GPI036/ADC1_CH0/RTC_GPI00
4	SVN	GPI039/ADC1_CH3/RTC_GPI03

5	P34	GPI034/ADC1_CH6/RTC_GPI04
6	P35	GPI035/ADC1_CH7/RTC_GPI05
7	P32	GPI032/XTAL_32K_P (32.768 kHz crystal input), ADC1_CH4/TOUCH9/RTC_GPI09
8	P33	GPI033/XTAL_32K_N (32.768 kHz Crystal output), ADC1_CH5/TOUCH8/RTC_GPI08
9	P25	GPI025/DAC_1/ADC2_CH8/RTC_GPI06/EMAC_RXD0
10	P26	GPI026/DAC_2/ADC2_CH9/RTC_GPI07/EMAC_RX_DV
11	P27	GPI027/ADC2_CH7/TOUCH7/RTC_GPI017/EMAC_RX_DV
12	P14	GPI014/ADC2_CH6/TOUCH6/RTC_GPI016/MTMS/ HSPICLK/HS2_CLK/SD_CLK/EMAC_TXD2
13	P12	GPI012/ADC2_CH5/TOUCH5/ RTC_GPI015/ MTDI/ HSPIQ/ HS2_DATA2/SD_DATA2/EMAC_TXD3
14	GND	Ground
15	P13	GPI013/ ADC2_CH4/TOUCH4/RTC_GPI014/MTCK/ HSPID/HS2_DATA3/SD_DATA3/EMAC_RX_ER
16	SD2	GPI09/SD_DATA2/SPIHD/HS1_DATA2/U1RXD
17	SD3	GPI010/SD_DATA3/SPIWP/ HS1_DATA3/U1TXD
18	CMD	GPI011/SD_CMD/SPICS0/HS1_CMD/U1RTS
19	5V	Power supply
20	CLK	GPI06/SD_CLK/SPICLK/HS1_CLK/U1CTS
21	SD0	GPI07/SD_DATA0/SPIQ/HS1_DATA0/ U2RTS
22	SD1	GPI08/SD_DATA1/SPID/HS1_DATA1/U2CTS
23	P15	GPI015/ ADC2_CH3/ TOUCH3/ MTD0/ HSPICS0, RTC_GPI013/HS2_CMD/SD_CMD/EMAC_RXD3
24	P2	GPI02/ADC2_CH2/TOUCH2/RTC_GPI012/HSPIWP/ HS2_DATA0/SD_DATA0
25	P0	GPI04/ADC2_CH0/TOUCH0/RTC_GPI010/HSPIHD/HS2_DATA1/S D_DATA1/EMAC_TX_ER Download mode: external pull down, running mode: suspended or external pull up
26	P4	GPI04/ADC2_CH0/TOUCH0/RTC_GPI010/HSPIHD/HS2_DATA1/S D_DATA1/EMAC_TX_ER

27	P16	GPI016/HS1_DATA4/U2RXD/EMAC_CLK_OUT
28	P17	GPI017/ HS1_DATA5/ U2TXD/ EMAC_CLK_OUT_180
29	P5	GPI05/ VSPICS0/ HS1_DATA6/ EMAC_RX_CLK
30	P18	GPI018/ VSPICLK/ HS1_DATA7
31	P19	GPI019/ VSPIQ/ UOCTS/ EMAC_TXD0
32	GND	Ground
33	P21	GPI021/VSPIHD/ EMAC_TX_EN
34	RX	GPI03/U0RXD/CLK_OUT2
35	TX	GPI01/U0TXD/ CLK_OUT3/ EMAC_RXD2
36	P22	GPI022/VSPIWP/UORTS/EMAC_TXD1
37	P23	GPI023/VSPID/HS1_STROBE
38	GND	Ground

5. Schematics

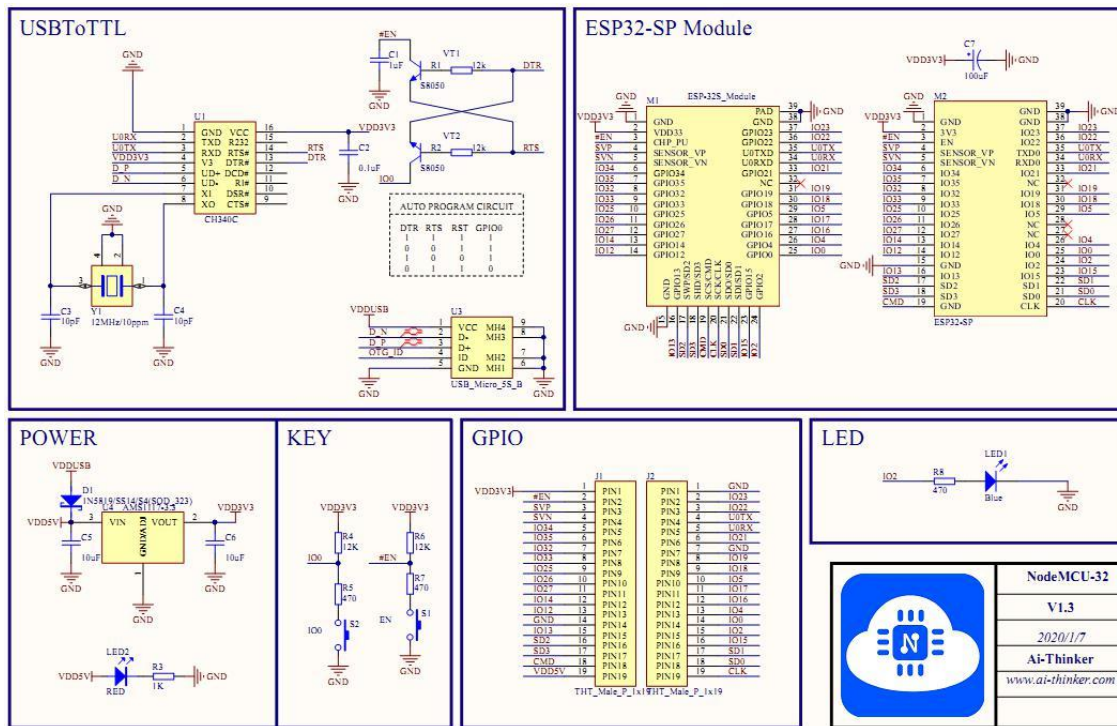

6. Design Guidance

6.1 Power Supply

- (1) Recommended voltage 3.3V, Peak: Current over 500mA .
- (2) It is recommended to use the LDO power supply; If DC-DC is used, the ripple is controlled within 30 mV.
- (3) DC-DC power supply circuit is recommended to reserve the position of the dynamic response capacitor, and the output ripple can be optimized when the load change is large.
- (4) Proposed addition of ESD Devices to 5V Power supply Interface.

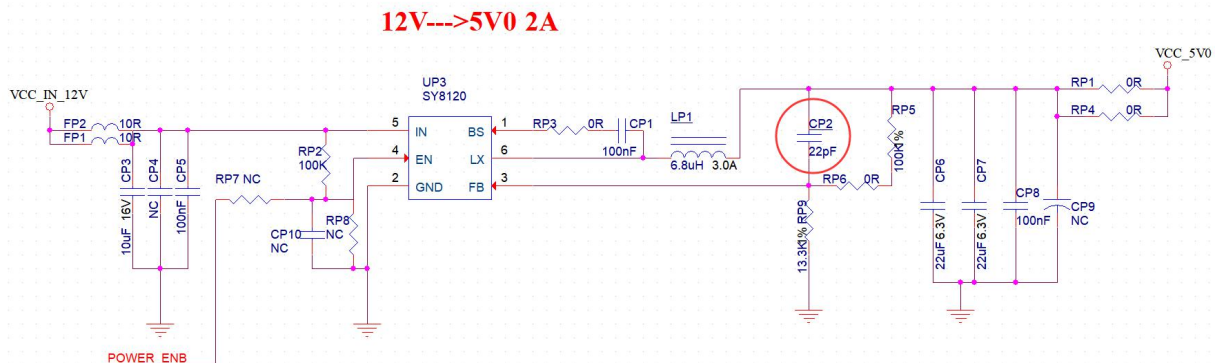

7. Reflow Welding Curve

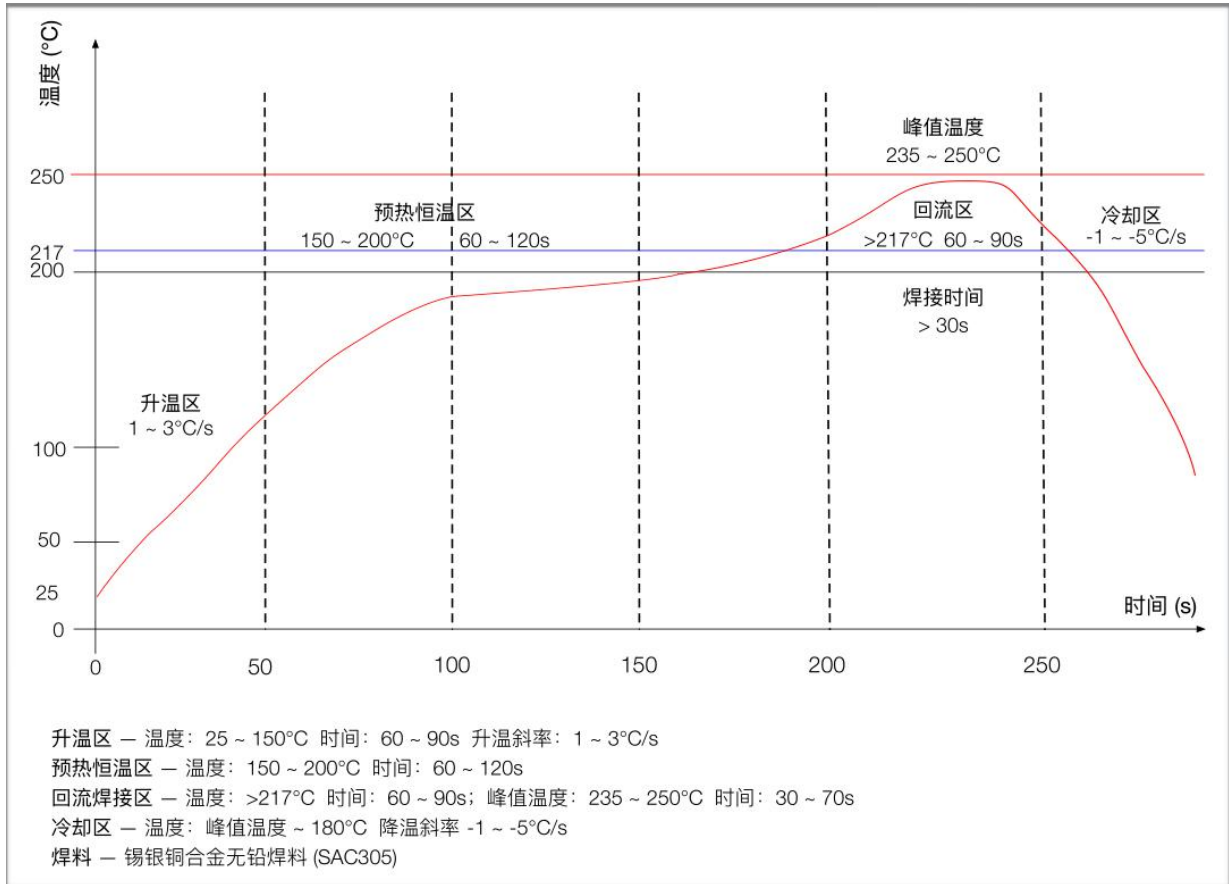

8. Package Information

NodeMCU-32_V1.3 development board is in anti-static bag.

9. Contacts

Company website: <https://www.ai-thinker.com>

Developer Wiki: <http://wiki.ai-thinker.com>

Company forum: <http://bbs.ai-thinker.com>

Sampling purchasing: <https://anxinke.taobao.com>

Business cooperation: overseas@aithinker.com

Technology support: support@aithinker.com

Company address: Room 403,408-410, Block C, Huafeng Smart Innovation Port, Gushu 2nd Road, Xixiang, Baoan District, Shenzhen.

Contacts: 0755-29162996

